

# Kane and Mele: Quantum Spin Hall effect.

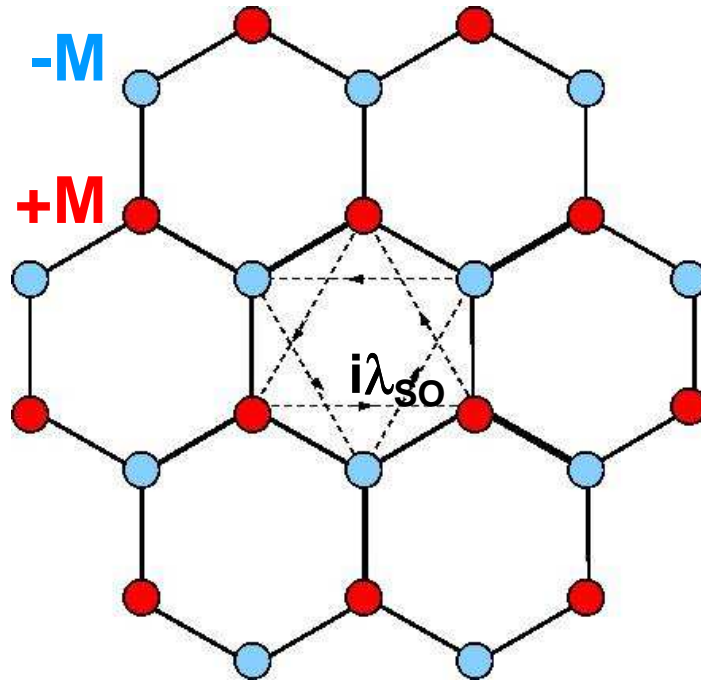

Charles Kane



**Spinful** fermions in a Graphene-like lattice model: 4-band model.

Inversion symmetry breaking (not really needed.)

**Spin orbit** term connecting sites in the same sublattice!

Hamiltonian obeys **time-reversal symmetry**.

A **Rashba spin orbit coupling** term can be added (results are qualitatively the same!)

C. L. Kane, E. J. Mele  
*Phys. Rev. Lett.* 95, 146802 (2005)  
*Phys. Rev. Lett.* 95, 226801 (2005).

[https://topocondmat.org/w5\\_qshe/fermion\\_parity\\_pump.html](https://topocondmat.org/w5_qshe/fermion_parity_pump.html)

# Kane and Mele model (no Rashba SOC)

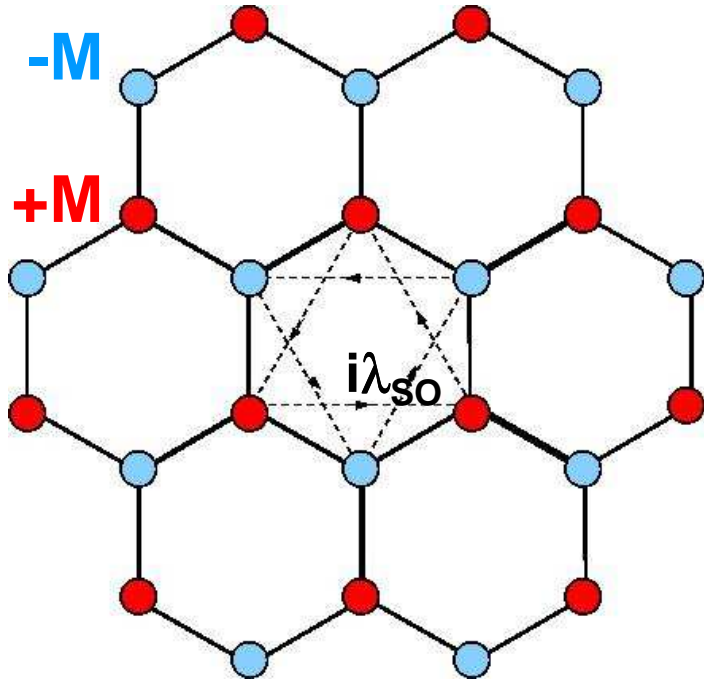

**Spin ↑** : essentially the Haldane model with  $\phi = \pi/2$

$$\frac{\mathcal{H}_{\mathbf{q}}^{\uparrow}}{N} = \begin{pmatrix} M + 2\lambda_{SO}f(\mathbf{q}, \frac{\pi}{2}) & t_1\gamma_{\mathbf{q}} \\ t_1\gamma_{\mathbf{q}}^* & -M + 2\lambda_{SO}f(\mathbf{q}, -\frac{\pi}{2}) \end{pmatrix}$$

$$\gamma_{\mathbf{q}} = 1 + e^{i\mathbf{q}\cdot\mathbf{a}_2} + e^{i\mathbf{q}\cdot(\mathbf{a}_2-\mathbf{a}_1)}$$

$$f(\mathbf{q}, \phi) = \cos(\mathbf{q}\cdot\mathbf{a}_1 + \phi) + \cos(\mathbf{q}\cdot\mathbf{a}_2 - \phi) + \cos(\mathbf{q}\cdot(\mathbf{a}_2 - \mathbf{a}_1) + \phi)$$

**Time-reversal symmetry:**  $\mathcal{H}_{\mathbf{q}}^{\downarrow} = \left(\mathcal{H}_{-\mathbf{q}}^{\uparrow}\right)^*$

$$\left\{ \begin{array}{l} (\gamma_{-\mathbf{q}})^* = \gamma_{\mathbf{q}} \\ f(-\mathbf{q}, \phi) = f(\mathbf{q}, -\phi) \end{array} \right.$$

**Spin ↓** : Haldane model with  $\phi = -\pi/2$

$$\frac{\mathcal{H}_{\mathbf{q}}^{\downarrow}}{N} = \begin{pmatrix} M + 2\lambda_{SO}f(\mathbf{q}, -\frac{\pi}{2}) & t_1\gamma_{\mathbf{q}} \\ t_1\gamma_{\mathbf{q}}^* & -M + 2\lambda_{SO}f(\mathbf{q}, \frac{\pi}{2}) \end{pmatrix}$$

# Kane and Mele: Quantum Spin Hall effect.

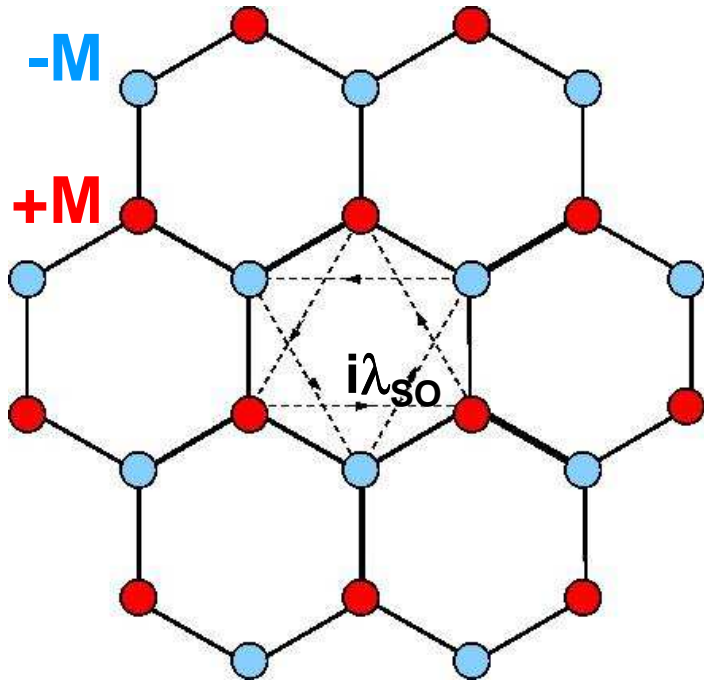

Gap:  $|6\sqrt{3}\lambda_{SO} - 2M|$

Topological phase :  $M < 3\sqrt{3}\lambda_{SO}$

Chern number  $n_s = \text{sgn}(s\lambda_{SO})$

$Z_2$  invariant  $\nu = \frac{1}{2}(n_{\uparrow} - n_{\downarrow}) = \pm 1$

New ingredients:

- Particles with spin  $s$ .
- Spin-Orbit coupling  $\lambda_{SO}$  (TRS preserved)
- Assuming no Rashba SO.

C. L. Kane, E. J. Mele  
*Phys. Rev. Lett.* 95, 146802 (2005)  
*Phys. Rev. Lett.* 95, 226801 (2005).

Spin-polarized  
Edge states

Topological

Non-Topological

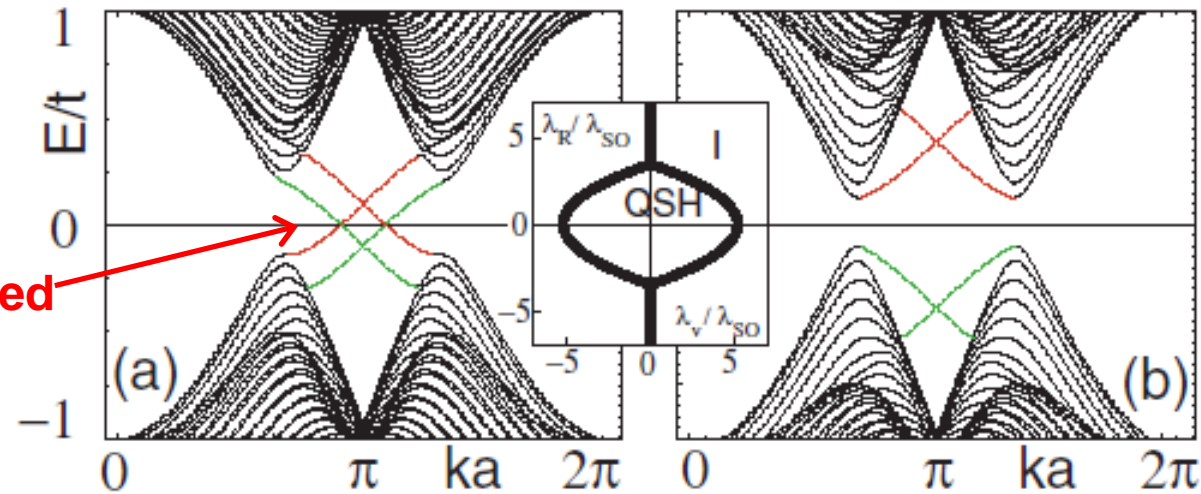

[https://topocondmat.org/w5\\_qshe/fermion\\_parity\\_pump.html](https://topocondmat.org/w5_qshe/fermion_parity_pump.html)

# HgTe Quantum Wells: “inverted” bands

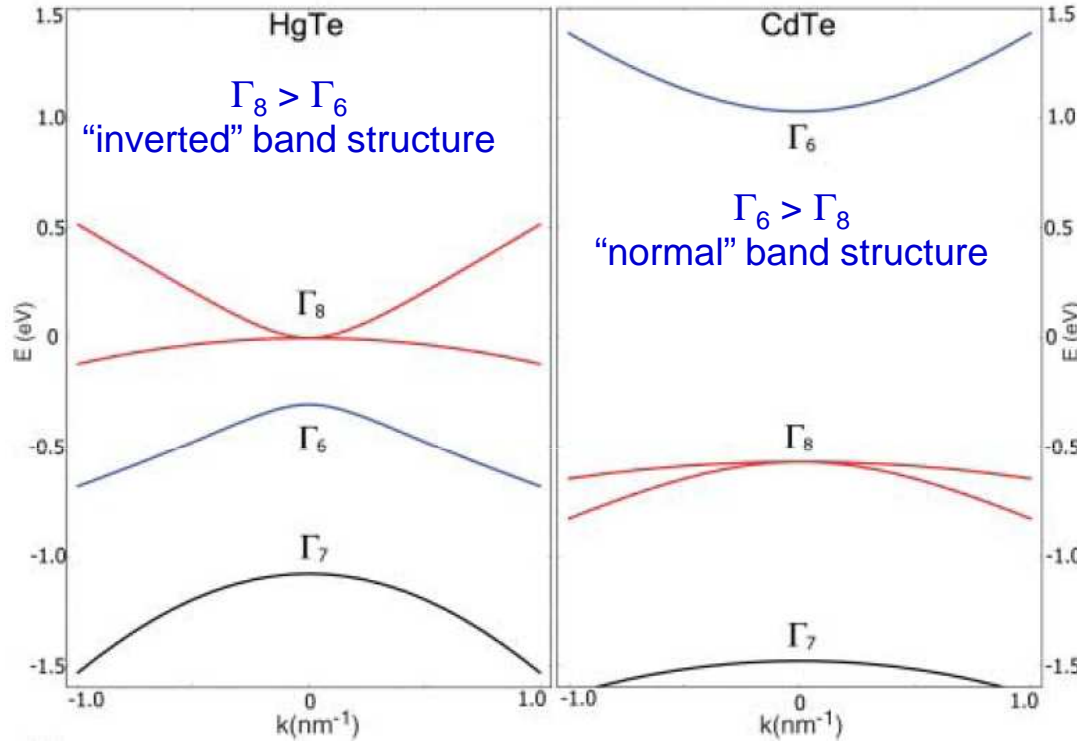

“ $\Gamma_6$ ”: s-type (s orbitals)  $S=1/2$

“ $\Gamma_8$ ”: p-type (p orbitals)  $J=3/2$   
 (“light and heavy holes”)

HgTe: “zero gap” semiconductor.

## HgTe quantum wells

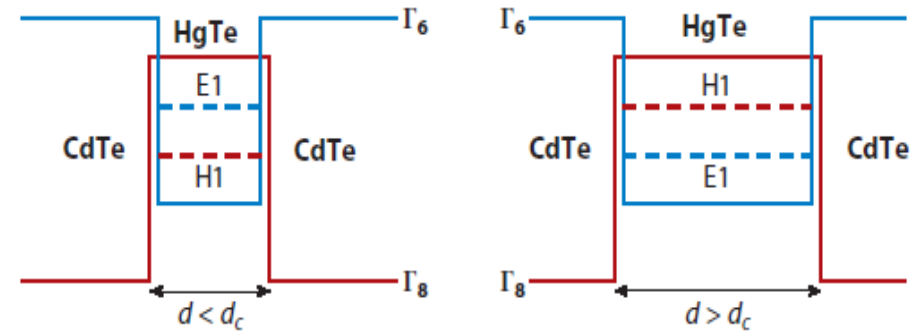
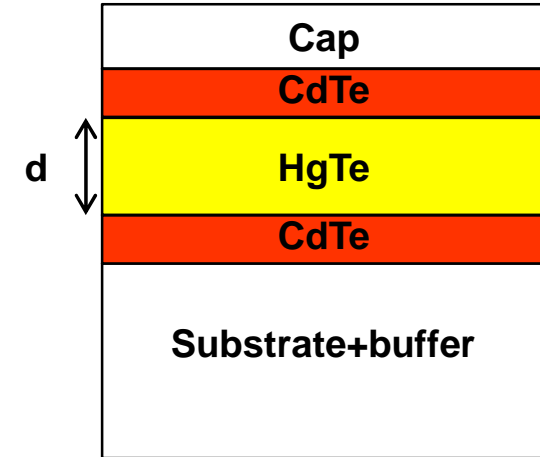

**Gap:**  $M \equiv E_{E1} - E_{H1}$

$d < d_c \Rightarrow M > 0$        $d > d_c \Rightarrow M < 0$

$d_c = 6.3 \text{ nm}$

# Effective model for HgTe QWs (BHZ).

Bernevig, Hughes, Zhang, *Science* 314, 1757 (2006)

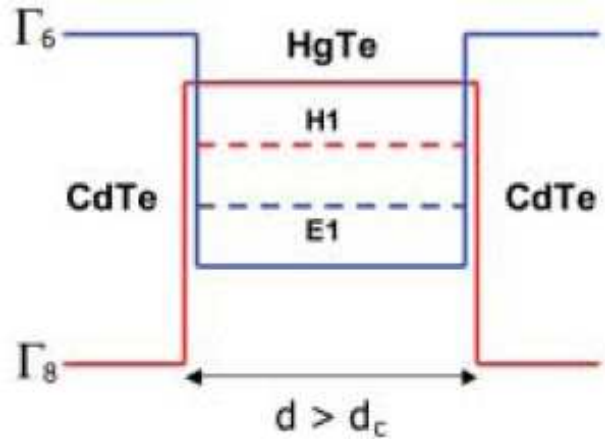

Basis:  $\left\{ \begin{array}{l} |E+\rangle \\ |H+\rangle \\ |E-\rangle \\ |H-\rangle \end{array} \right.$

Basis functions:  $\left\{ \begin{array}{l} \Psi_{\mathbf{k}}^{E+}(\mathbf{r}) \\ \Psi_{\mathbf{k}}^{H+}(\mathbf{r}) \\ \Psi_{\mathbf{k}}^{E-}(\mathbf{r}) \\ \Psi_{\mathbf{k}}^{H-}(\mathbf{r}) \end{array} \right.$

Hamiltonian (low energy from  $\mathbf{k}\cdot\mathbf{p}$  theory):

$$\mathcal{H}(\mathbf{k}) = \begin{pmatrix} h_+(\mathbf{k}) & 0 \\ 0 & h_+^*(-\mathbf{k}) \end{pmatrix}$$

$$h_+(k_x, k_y) = \begin{pmatrix} \epsilon(k) + \mathcal{M}(k) & Ak_- \\ Ak_+ & \epsilon(k) - \mathcal{M}(k) \end{pmatrix}$$

$$\left\{ \begin{array}{l} \epsilon(k) = C - Dk^2 \\ \mathcal{M}(k) = M - Bk^2 \\ k_{\pm} = k_x \pm ik_y \end{array} \right.$$

$d$ (Å)	$A$ (eV)	$B$ (eV)	$C$ (eV)	$D$ (eV)	$M$ (eV)
58	-3.62	-18.0	-0.0180	-0.594	0.00922
70	-3.42	-16.9	-0.0263	0.514	-0.00686

$d < d_c$   
 $d > d_c$

Table 1: Parameters for  $\text{Hg}_{0.32}\text{Cd}_{0.68}\text{Te}/\text{HgTe}$  quantum wells.

# Quantum Spin Hall effect in HgTe QWs.



Shoucheng Zhang

Gap:  $|E_{E1} - E_{H1}| \equiv |M|$

Chern number

$n_s = \text{sgn}(M)$

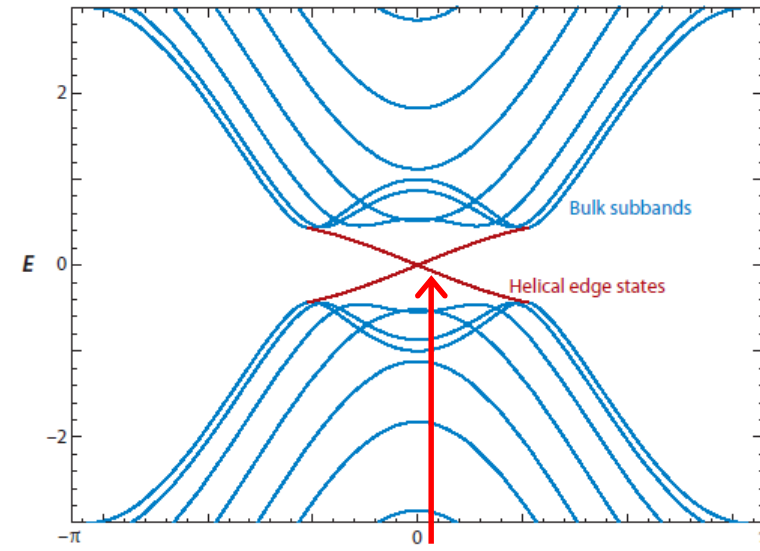
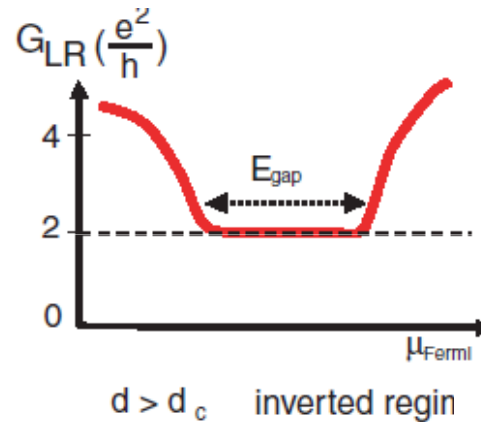
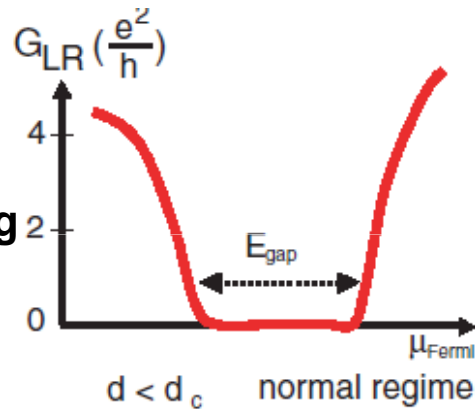

Spin-polarized Edge states

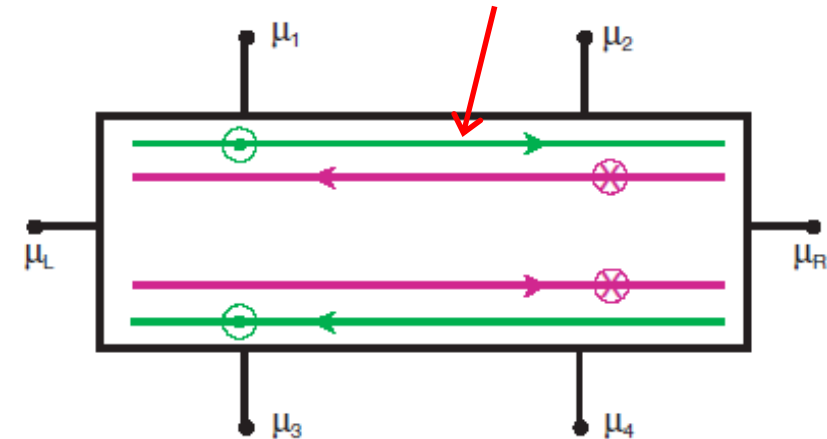

$$\Delta\sigma_{xy} = 2\frac{e^2}{h}$$



Andrei Bernevig

# QSH effect in HgTe QWs: Experiment



Laurens Molenkamp

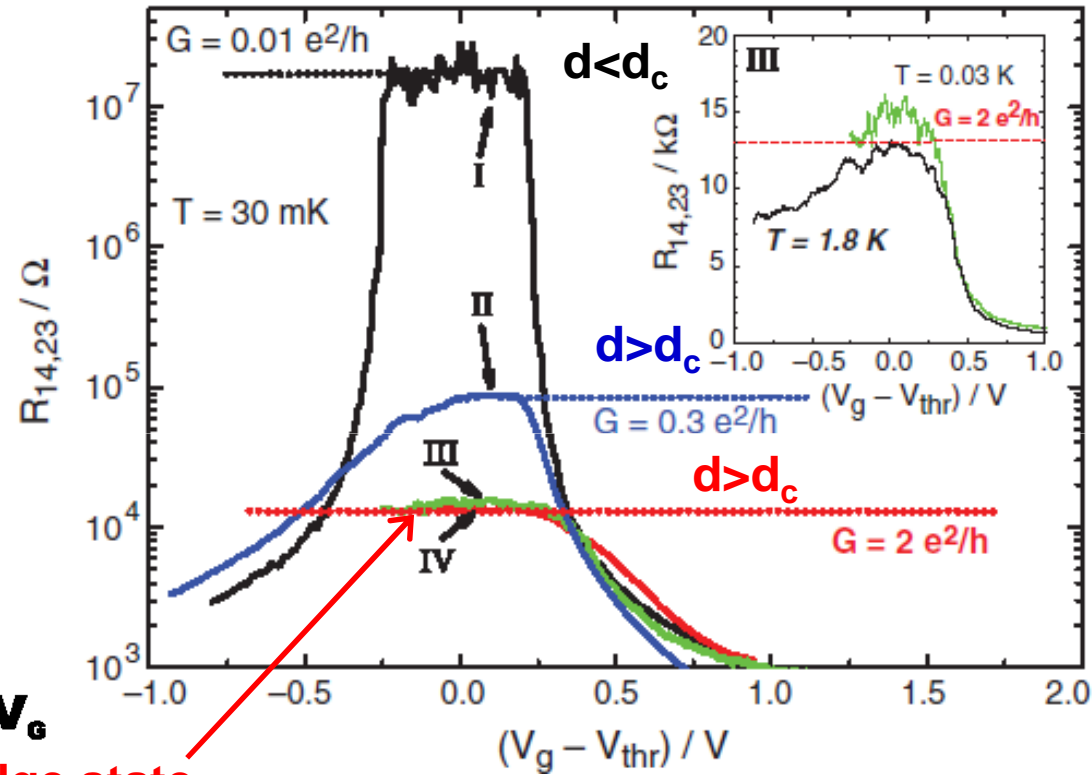
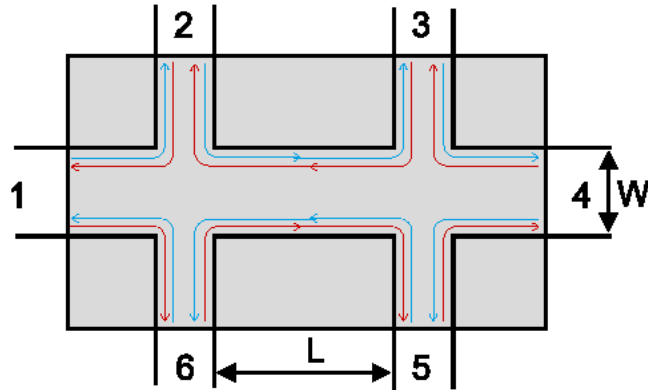

König et al, *Science* 318, 766 (2007)

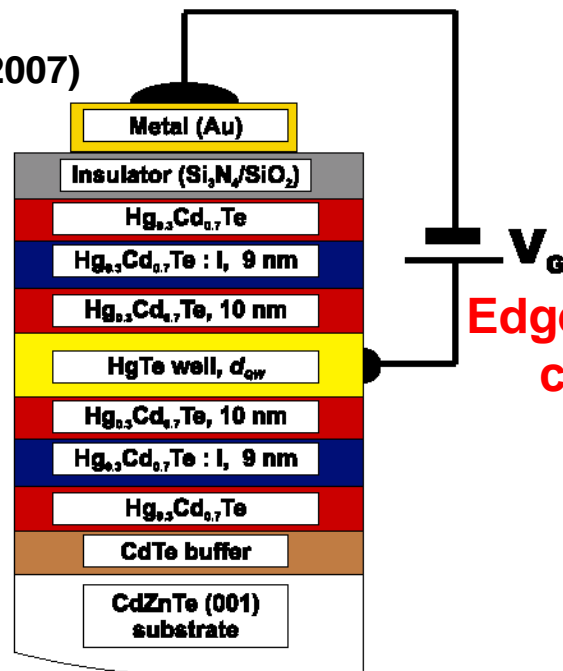

Edge state  
conductance

- I-L=20  $\mu\text{m}$  W=13  $\mu\text{m}$  ( $d < d_c$ )
- II-L=20  $\mu\text{m}$  W=13  $\mu\text{m}$  ( $d > d_c$ )
- III-L=1  $\mu\text{m}$  W=1  $\mu\text{m}$  ( $d > d_c$ )
- IV-L=1  $\mu\text{m}$  W=0.5  $\mu\text{m}$  ( $d > d_c$ )

# A future Nobel Prize?

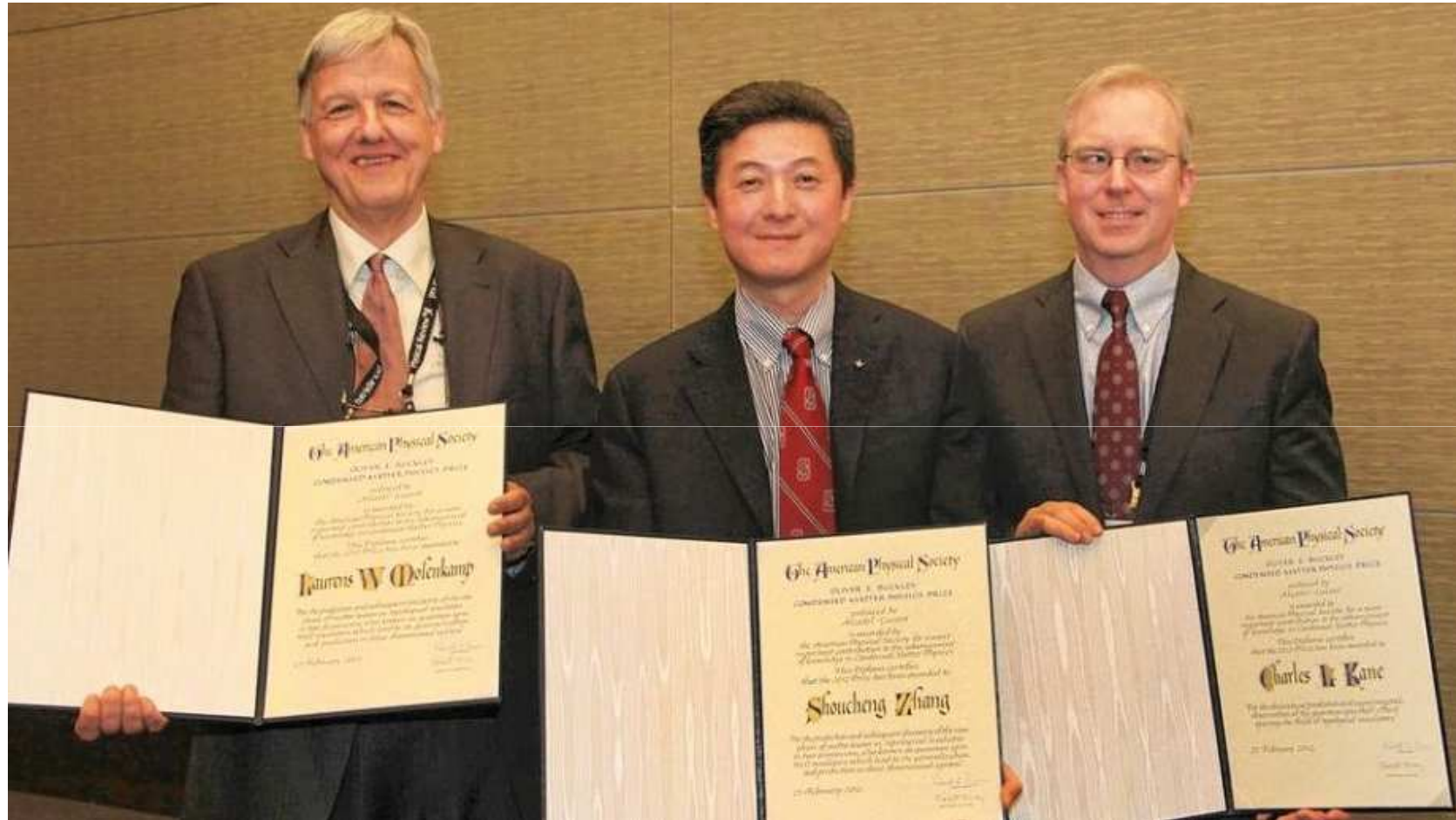

**Physics Frontiers Prize 2013**

**also: APS Buckley Prize 2012**